

WARTUNG VON GELENKWELLEN

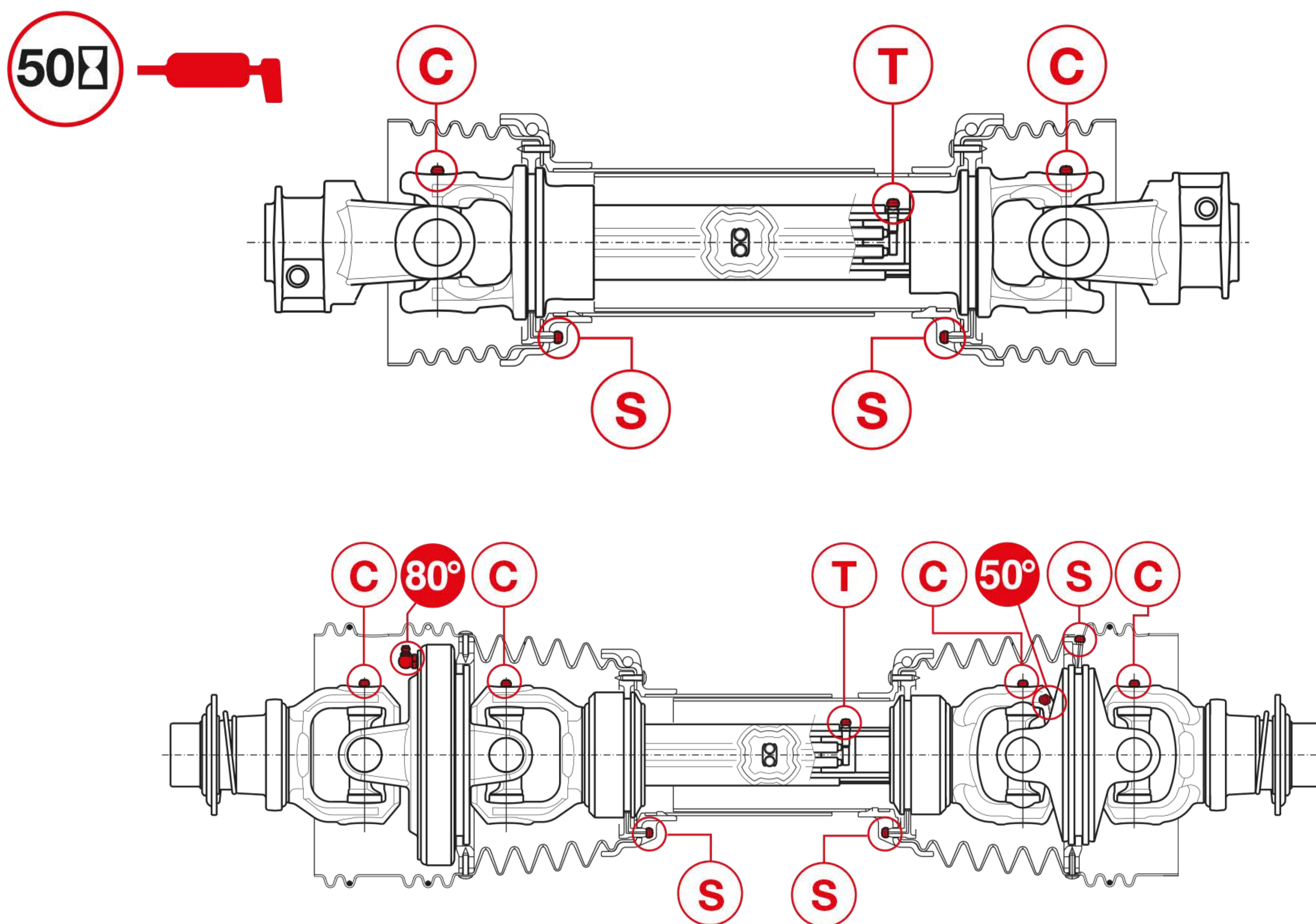

SCHMIERPLAN – BONDIOLI & PAVESI SERIE SFT

SCHMIERINTERVALLE (STUNDEN) UND UNGEFÄHRE FETTMENGEN



BONDIOLI & PAVESI

	S1	S2	S4	S5	S6	H7	S8	H8	S9	SH	S0	
Kreuzgelenke (C)	4 g	7g	10g	13 g		18 g	22 g		26 g	28 g	30 g	
Gleitringe d. Schutzvorr. (S)							6 g					
Profilrohre (T)	12 g	20 g				32 g						
Weitwinkelgelenk 80° (80°)		20 g	30 g			60 g	80 g		100 g	160 g		
Weitwinkelgelenk 50° (50°)			5 g			6 g	7 g		8 g			